

16394 U.S. 224 - P.O. Box 299 • Kalida, Ohio 45853
 419/532-3647 • 800/537-7370
www.remlingermfg.com

PFM

ECONOMICAL TO OWN EASY TO OPERATE

Series 400 - Center Cut & Offset Power Ditchers Spring Tensioned - **BELT DRIVE**

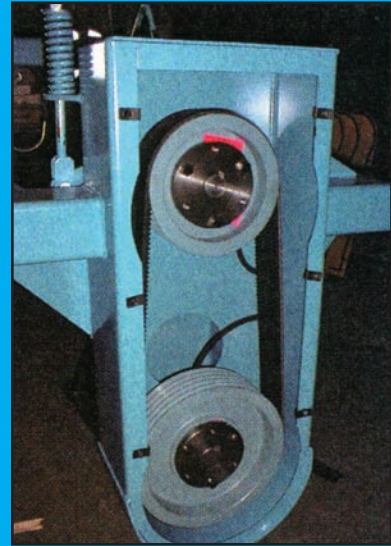

PERFORMANCE:

The rugged PFM power ditcher is the simplest, most economical approach to field water control. Designed to spread soil up to 30 ft. and dig ditches up to 12" deep in one pass. Excellent performance in most soil conditions and all types of crops.

DURABILITY:

The unique high HP belt drive is equipped with a banded belt, tapered bushed sheaves and self-adjusting spring tensioning system. Rotor has labyrinth shielded bearings and four reversible cutting blades. These features make the PFM power ditcher the strongest and most durable on the market.

CONVENIENCE:

The simple spring tensioned self-adjusting belt drive assures proper tension, resulting in little down time for service or maintenance. No more difficult alignment, adjusting and leak problems normally caused by high RPM chain drive systems.

Series 400 Specifications

Model	400-10	400-20	400-30
Recommended PTO HP	35 min	35 min	35 min
PTO tractor yoke	1-3/8 6 spline 540 RPM	1-3/8 21 spline 1000 RPM	1-3/4 20 spline 1000 RPM
Drive shaft	180 HP shear pin with regreaseable slide		
Cutting head	Equipped with 4 reversible high carbon blades, adjustable from 18"-20" dia.		
Hitch	Fits category II and III standard or quick hitch systems		
Weight	Approx. 850 lbs.		

ECONOMICAL TO OWN EASY TO OPERATE

Series 600 Bale Slicer

Skid Steer Design



PERFORMANCE:

The rugged PFM Bale Slicer cuts bales of hay, straw or silage quickly and efficiently, for indoor or outdoor feeding or bedding of dairy or beef cattle. Bales are sliced open in a few seconds and chopped into loose hay in a couple of minutes. The four bale spears securely carry the bale from storage to feeding location. With minimum maintenance this bale slicer will give excellent performance for many years.

CONVENIENCE:

The rugged PFM Bale Slicer selects, picks up, carries and slices bales for efficient and fast feeding or bedding of animals with minimum down time and service.

OPTIONAL EQUIPMENT:

3-point hitch fits all category 2-3 tractors.

Series 600 Specifications

Series 600 Specifications	
Weight	680 lbs.
Open Height	8' 6"
Max Bale Width	5' 7"
Max Bale Height	6' 0"
Knife Length	7' 4"
Lift Capacity	2500 lbs.
Pivot Points	Bronze Bushings on Knife Pivot
HYD. Cylinder	3 1/2" Diameter X 20" Stroke
Required Hydraulics	One Pair of Auxiliary Outlets

Series 200 Post & Tree Puller

PERFORMANCE:

The rugged PFM Post & Tree Puller is a simple, economical approach to pulling posts and trees. Designed to pull trees from 1" to 6" diameter and posts from 1" to 12" diameter with the high lifting capacity on both tractor 3 point and skid steer loaders. The result is excellent performance in most conditions.

DURABILITY:

Pivot shaft is 2" diameter cold rolled stress-proof material. The unique jaws and clamps are grade 50 steel and equipped with maintenance-free bronze bushings at pivot points. These features make the PFM Post & Tree Puller the most durable on the market.

CONVENIENCE:

The simple self-aligning jaw clamps will center post or tree when clamping. This unique jaw-clamping system gives the user the convenience to control post and tree puller functions without leaving the tractor or skid loader.

OPTIONAL EQUIPMENT:

Skid loader to 3-point adapter kit. Cushion pad assembly (excellent when used with skid loader for moving, loading or unloading to control tree damage at tree nurseries, etc).

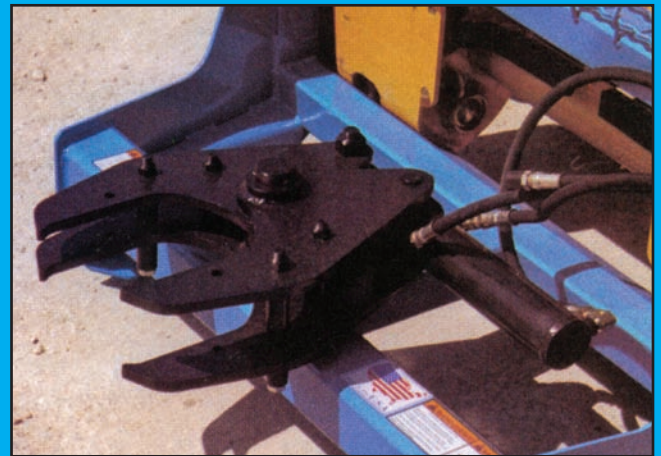

Series 200 Specifications	
Model	200-300
Weight	425 lbs.
Tree Diameter	1 inch to 6 inch
Post Diameter	1 inch to 12 inch
Lift Capacity	All category 2 three-point tractors & All skid steer sizes
Pivot Points	Maintenance free bronze bushings

Series 700 Screening Bucket

Skid Steer Design

PERFORMANCE:

The PFM Screening Bucket is ideal for commercial and residential landscaping, farms, industrial uses, golf courses, baseball fields, beaches and many other applications. It will screen dirt, gravel, sand, demolition debris, large rocks and many other materials. By screening and compacting at the site, contractors can prepare sub-grade surfaces. Utility and trenching contractors can screen bedding material. Useful for digging, loading, and carrying materials after unwanted fines have been removed. The simple rugged design results in minimum downtime for service and maintenance.

DURABILITY:

The quick-change replaceable screen cloth is available in various sizes of openings and made of long lasting, high carbon alloy steel. The hydraulic vibrator with greasable bearings provides power to shake heavy materials. An adjustable flow divider with pressure relief valve allows fine tuning of vibrator speed to match the hydraulics of the skid loader. These features make the PFM Screening Bucket one of the strongest, most durable on the market.

CONVENIENCE:

Investment in a PFM Screening Bucket will greatly increase the speed of any type of rubble or rock type material screening, whether it is an agricultural, industrial, commercial or landscaping operation. Simple hydraulic connection that does not require access to a case drain on the skid loader and the adjustable hydraulic flow control provides the user with easy setup.



Series 700 Specifications		
Series	700-20	700-30
Width	60"	70"
Screen Opening Size	1/8" sq. up to 5" sq.	
Capacity	3/4 Cubic Yds.	7/8 Cubic Yds.
Weight	1050 lbs.	1100 lbs
Hydraulic Vibrator	Requires 13-16 gpm at 1500 psi	
Required Hydraulics	Fits most skid-steer loaders with bi-directional auxiliary hydraulics	

Series 500-55

Multi-Purpose Fork Bucket

Skid Steer Design

PERFORMANCE:

The unique PFM Multi-Purpose Fork Bucket is skid steer designed for numerous applications such as agricultural, commercial, industrial or landscaping. This universal bucket is an efficient, economical approach to digging, picking, loading, leveling and grapple-type work. The simple design and straight-forward action results in a highly reliable machine with minimum maintenance and excellent performance for years to come.

DURABILITY:

The bucket tines are high carbon, hard surfaced 1-1/4 inch square teeth. Tines extend to the rear of the bucket spaced 2 inches apart creating a grated bottom allowing dirt to escape. The reel is powered with a 2 inch bore x 20 inch stroke cylinder with built in cross over pressure relief valve, eliminating shock loads. These features make the PFM Multi-Purpose Fork Bucket one of the strongest, most durable on the market.

CONVENIENCE:

Investment in a PFM Multi-Purpose Fork Bucket will greatly increase the speed of any type of rubble or rock type picking, whether it is an agricultural, industrial, commercial or landscaping operation. The simple hydraulic cylinder and reel system provides the user with minimal required downtime for service or maintenance.



Series 500-55 Specifications

Series 500-55 Specifications	
Width	56" (other sizes available)
Rock Size	2" to 24"
Capacity	5/8 cubic yards
Weight	930 lbs.
Hydraulics	2" bore X 20" stroke cylinder
Required Hydraulics	Fits most skid-steer loaders with bi-directional auxiliary hydraulics

Series 500 Rock Picker Hydraulic Powered



PERFORMANCE:

The rugged PFM Hydraulic Powered Rock Pickers are the simplest, most economical approach to continuous picking machines for stones, rocks, windrows and boulders. The simple design and straight forward picking action results in a highly reliable machine with minimum maintenance and excellent performance for years to come.

DURABILITY:

The rugged double wrap around frame is all welded and constructed from heavy wall 5" square tubing. The reel assembly features spring cushion action, individual hard surfaced teeth with heavy wall tube and carbon shafting and pins. The heavy duty pivot bucket hinges provide high strength and hopper stability. These features make the PFM rock picker the strongest and most durable on the market. It is built to stand up to the extra abuse demanded of rock removal equipment.

CONVENIENCE:

Rock removal equipment is essential to modern farming practice. Investment in a PFM rock picker will greatly reduce down time and damage to tillage and harvesting equipment. The simple, highly efficient valve and remote switch box hydraulic system gives the farmer the convenience to control all rock picker functions separately without leaving the tractor.

SWING HITCH:

A standard 3x8 hydraulic cylinder positions the rock picker for rock alignment or shifts the machine into transport position without the operator leaving the tractor.



IMPLEMENT HITCH:

Category 3 rated at 4,009 vertical pounds and 56,888 draft pounds. Clevis is standard with hitch, rated at 12,586 pull pounds and fits 1" drawpin size.

HYDRAULIC REEL DRIVE:

Has several important advantages over PTO drive systems including safety, no vibration and sharper turning. The reel can be reversed for clearing. The hydraulic motor has a built-in cross over relief valve, eliminating shock loads. RPM of reel can be varied by changing the volume of oil without changing tractor ground speed. Tractor hydraulic requirements: 12 GPM@1500 PSI with dual hydraulic system.

BAR REEL AND SCOOP ASSEMBLY:

Features high carbon steel with individual hard-surfaced teeth. The reel is equipped with heavy duty tines and spring cushion trip action. The large diameter reel and longer tines on scoop are positioned to provide easy pick up and more efficient transfer of rock to the bucket. The design and heavy construction will give the user years of continuous and efficient rock picking in tough conditions.

HYDRAULIC CYLINDERS:

The dual system provides smooth even lift when picking stubborn rocks or dumping on uneven terrain. Hoses from implement to tractor are included.

Two are provided on tine scoop (3x8) and two on the hopper lift (3 1/2x30).



Series 500-20 Specifications

Frame	Welded construction using heavy plate and 5" square tube
Hopper	Constructed with grated bottom and 1/4" steel gusseted back
Rock Guard	Heavy 1/2" thick rubber deflector
Hopper Size	2 1/4 cubic yard
Tine Scoop	Specially designed, hard surface contoured tine
Bar Reel	Large diameter with hard surfaced teeth, protected by heavy duty spring cushion trip action
Swing Hitch	Hydraulic controlled from tractor
Implement Hitch	Category 3 with clevis
Hydraulics Scoop	Two 3 x 8 cylinders
Hydraulics Swing Hitch	One 3 x 8 cylinders
Hydraulics Hopper	Two 3 1/2 x 30" cylinders
Reel Drive	Hydraulic motor with cross over relief valve
Tractor Hydraulics	Two remotes required - 12 GPM at 1500 PSI min with flow control
Axel & Hub	7500# hub & axle assembly
Tire Size Optional Tire Size	Standard 10 ply x 12.5L x 15 Optional 385/65R x 22.5 used
Tractor HP	60 HP minimum
Rock Size	1 1/2" to 24"
Picking Width	60"
Transport Length & Width	17' 6" X 9' 8"
Weight	4800#

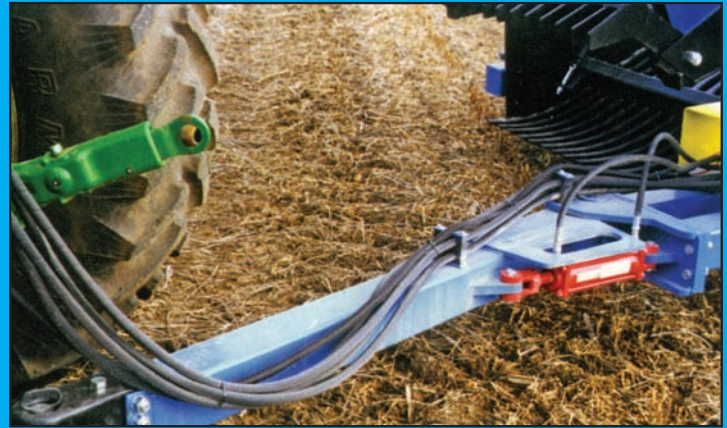

VALVE AND REMOTE SWITCH BOX

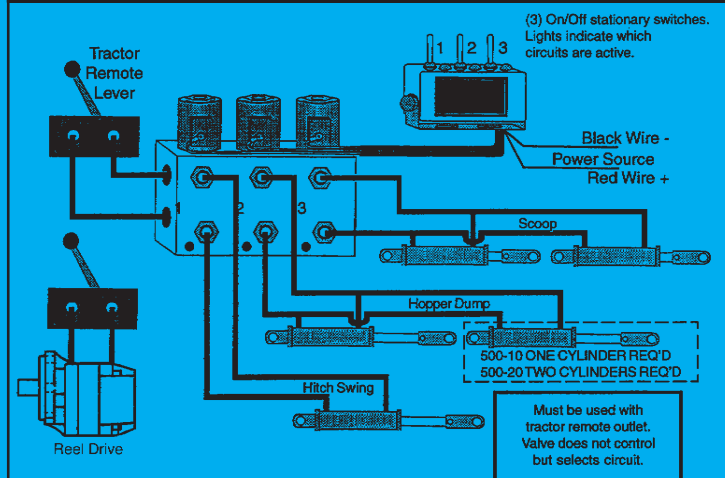

REMLINGER MANUFACTURING COMPANY, INC.

16394 U.S. 224 - P.O. Box 299 • Kalida, Ohio 45853 • 419/532-3647 • 800/537-7370

www.remlingermfg.com